



NANSLEDAN
DESIGN AND COMMUNITY CODE



DUCHY *of* CORNWALL

February 2023

A note to new residents from the Duchy of Cornwall

Welcome to Nansledan! We hope very much that your decision to live here reflects your appreciation of what we are trying to do to make Nansledan a genuinely liveable community—a place that will continue to be treasured as it matures over the centuries that lie ahead.

This booklet is really important as it explains the philosophy and reasons behind the strong controls that the Duchy of Cornwall retains at Nansledan. If you have ideas on how to improve your property or are planning on making any alterations to it please make contact with the Duchy of Cornwall first so that we can help guide you forward with a successful application for consent.

With best wishes,

Duchy of Cornwall Team at Nansledan

Website: www.nansledan.com

Introduction

- The Design & Community Code

1.0 The Legal and Management Framework

2.0 Guidance for Extensions

3.0 Building Materials and Details

4.0 External Walls

- Stone
- Slate Hanging
- Timber
- Brick
- Render
- Alternative Materials
- Mortar
- Lintels
- Copings
- Party Walls
- Control & Expansion Joints
- Airbrick & Weepholes
- Doors & Porches
- Windows

5.0 Roofs and Chimneys

- Dormer Windows
- Roof lights
- Rainwater Goods, Gutters & Plumbing
- Chimneys

6.0 Outbuildings

7.0 Boundary Walls, Fences and Gardens

8.0 Ancillary Elements

- Lettering

9.0 Business Premises

10.0 Accessibility

11.0 Environmental Issues

12.0 Utilities

13.0 Cornish Language

14.0 Bird, Bat, Bee and Other Habitats

15.0 Edible Planting

16.0 Making Your Application

APPENDICES

Appendix A – Estate Stipulations

Appendix B – Community Stakeholder Covenants

Appendix C – Lettering on Homes and Streets

Appendix D – Lettering on Shopfronts

Appendix E – Approved Paint Colours

For further information,
please visit our website:
www.nansledan.com

Introduction

You have probably already noticed that Nansledan has a character more distinctive than the average development. This is the result of a cohesive philosophy during the design of the masterplan and strong controls in the management of the built neighbourhood. We are here to help you to keep Nansledan special and protect this unique space.

The Design & Community Code

Each building in Nansledan has been designed to achieve individuality and harmony within the overall vision of a beautiful, traditional and vibrant Cornish urban community. The masterplan framework is captured in the Nansledan Local Development Order (2021)* Design Manual, which includes the Newquay Pattern Book,

Green Infrastructure Strategy and Highway Key Design Details. The vision for Nansledan takes a more holistic approach to sustainable development, through the durability of natural materials and traditional techniques which incorporate high levels of insulation and energy efficiency. For example, the use of local Cornish and recycled materials are prioritised to reduce the amount of carbon in constructions (see graphic on opposite page). By maximising the use of local supply chains, Nansledan bolsters the local economy and creates jobs in its construction and operation.

This Design and Community Code (“Code”) is intended to give confidence to owners and occupiers that the appearance of the development and the principles of sustainability will be protected

over time, and if change is sought the Duchy will regulate this to maintain the high standards for the benefit of all. The guidance set out in this Code incorporates the relevant provisions of the LDO Design Manual.

*The Nansledan Local Development Order (2021) (“Nansledan LDO”) grants permitted development rights for alterations and development proposals that would normally require additional planning permission. **However, in order to carry out development (including extensions to property), a Certificate of Conformity with the LDO must first be issued by the Duchy of Cornwall. In addition to this, minor alterations (permitted development) are covered by the Stipulations and require prior approval from the Duchy.**



The Nansledan Design Manual and appendices

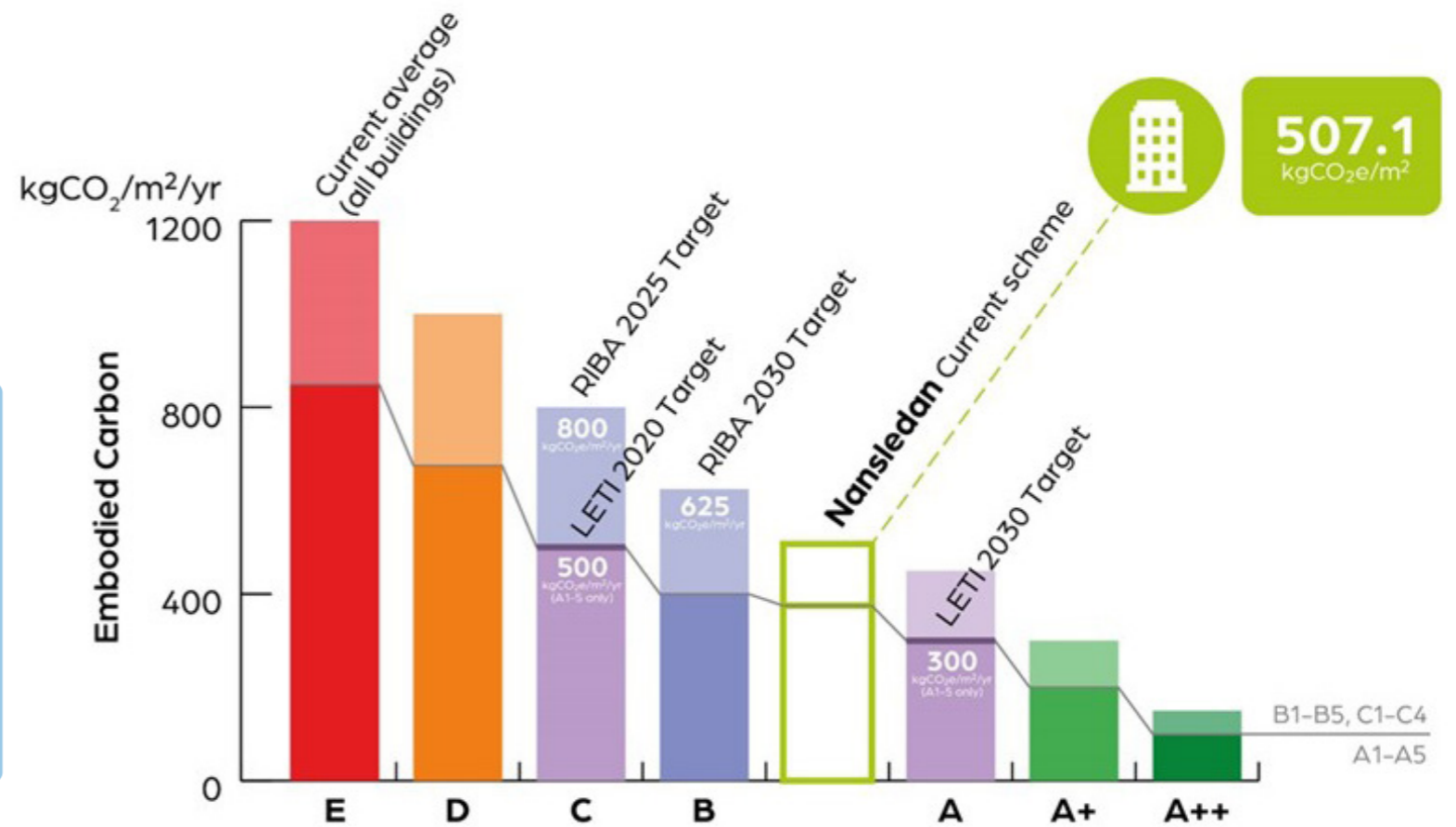

Example of Embodied Carbon in the construction of a 3 Bed home in Nansledan compared with industry standards and draft performance targets as Spring 2022

1.00 The Legal and Management Framework

- 1.01 **The purpose of this Code is to draw attention to the Estate Stipulations (“the Stipulations”), incorporated into the legal title and Estate Deed.** The Stipulations apply to both freehold and leasehold properties. The Stipulations should be read in conjunction with the Community Stakeholder Covenants (set out in the Planning Agreement for Nansledan). The Stipulations provide for each freeholder and tenant (both long-term and short-term tenants) to be provided with the Code so that they are fully aware of the Stipulations and the Community Stakeholder Covenants, enclosed at Appendix A and Appendix B respectively.
- 1.02 **The conclusion of each sale or rental agreement initiates the obligation to observe the Stipulations imposed by the Duchy of Cornwall: not to alter or extend the exterior of a property without the Duchy’s written approval.** The Stipulations are binding for all properties, their owners and occupiers. As and when new buildings are completed, purchasers are supplied with the Stipulations so that all owners and occupiers are aware of them. Breaches of the Stipulations could result in enforcement action and may prejudice the sale of individual properties.
- 1.03 **The Stipulations are enforceable by the Duchy and the Estate Management Companies.** The application process is described at the end of this Code.
- 1.04 All matters relating to the construction of buildings and use of land constitute ‘development’ and, as such, are brought under the statutory planning regime covered by the Nansledan Local Development Order (2021). However, for owners and occupiers, there is an exemption for minor matters, such as small extensions. Thus, alterations to residential properties at Nansledan, including the construction of small extensions, the removal and changing of windows and doors, insertion of dormer windows on rear roof slopes, erection of porches, or retiling roofs in modern materials, do not require express planning permission. However, this does not exempt the work from control by the Duchy. **Permitted development is covered by the Stipulations and requires prior approval from the Duchy.**

- 1.05 The Nansledan Estate is to be developed in Quarters, which in turn comprise Phases. **Three Management Companies have been set up to manage and provide services in respect of the Estate at Nansledan, namely the Nansledan Estate ManCo (to cover site wide Green Infrastructure), the Nansledan North and Nansledan South Management Companies with between them the remaining public realm in each Quarter.** Owners of residential, commercial and community properties will become members of the Management Companies and will enter into Estate Deeds with the relevant Management Company. The Estate Deeds cover the provision of services by Management Companies and each owner’s obligation to pay the relevant service charge.
- 1.06 Cornwall Council is the planning authority for Nansledan. **Cornwall Council has granted planning permission for the construction of the development, covering every individual building, its use and use of the land through the Nansledan Local Development Order (2021).** However, any works that would normally require planning permission and which have been authorised under the LDO will require a **Certificate of Conformity from the Duchy of Cornwall prior to commencement.** The Nansledan development is outlined in the Masterplan which identifies the Quarters, Phases and proposed land uses. The Duchy of Cornwall and Consortium may vary the Masterplan, the Quarters and proposed uses from time to time.
- 1.07 **The images of the proposed development in this Code are indicative only and not definitive.** They are not, and should not be treated as, representations as to the final design and appearance of all or part of the development.

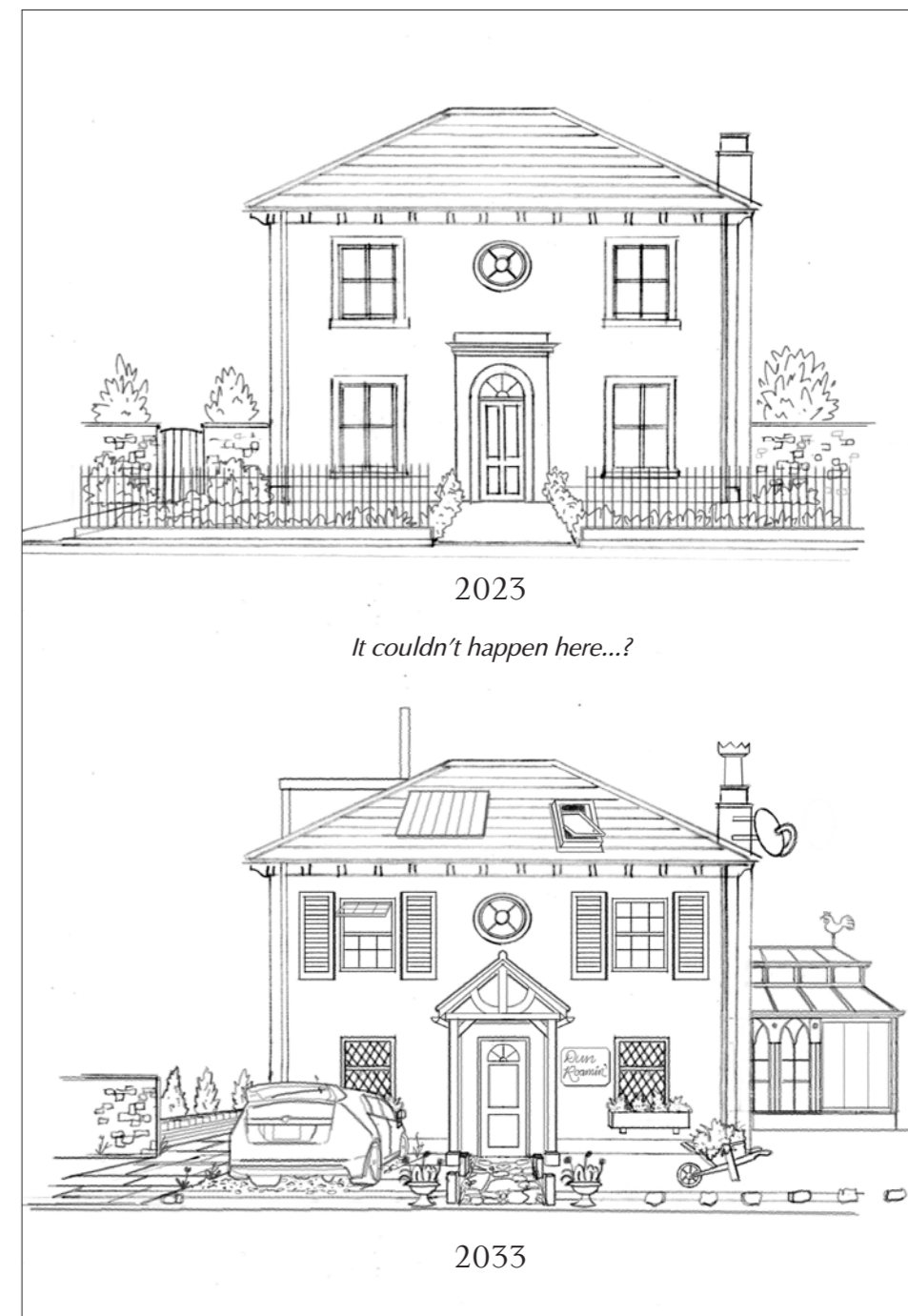

2.00 Guidance for Extensions

2.01 Every house at Nansledan has been designed to provide accommodation which will meet the needs of owners and occupiers. However, it is recognised that individual taste varies, and that needs change over time, for example addition to a family, retirement, or working from home. There may be a perception that more room is required. It may be possible to reorganise internal space, without affecting the exterior of the building. Occasionally owners may conclude that an extension, or a loft conversion is the solution. There may also be applications to add conservatories to houses, to erect a garden shed or closed-in car ports.

- a. *All proposals for external alterations, loft conversions, extensions, conservatories, garden sheds, car port infilling, the addition of Photovoltaic Panels (PV's), or indeed anything that may alter the external appearance of the property will require consent from the Duchy.*

The close spacing of the buildings, compact gardens, and overall design concept at Nansledan will strictly limit the scope for such work. In considering such applications, the impact on the integrity of the building concerned will be assessed, together with the effect on neighbouring properties, and the character and appearance of the surroundings, particularly where designed groups of buildings are involved. In all of this the Duchy will always be concerned to ensure that your neighbours will also be happy.

2.02 Every property at Nansledan has been designed to address the street. The continuity of frontage is continued by boundary walls to create an urban sense of enclosure.

- a. *No front projecting extensions, or enclosed porches will be allowed, unless they were part of the original house.*

2.03 The terraced configuration of many properties will strictly limit the scope for side extensions. In cases where such extensions will be allowed, they will comply with the following principles:

- a. *The extension is clearly perceived to be subservient to the original building, complementing, not competing with its presence in the street picture;*
- b. *The building frontage line is respected;*
- c. *The form, materials and detailing of the extension match those of the existing house;*
- d. *The extension does not adversely affect the privacy or amenity of neighbouring properties.*

2.04 Rear extensions are the most likely to be contemplated, and to be found acceptable. It should be borne in mind, however, that the design of back elevations, and grouping of properties, has been as carefully considered as the fronts. The appearance from the mews or parking courtyards is as important as the street scenes. To be acceptable, rear extensions must comply with the following principles:

- a. *The extension is clearly perceived to be subservient to the original building, complementing, not competing, with its overall form;*
- b. *The form, the materials and detailing either match or complement those of the existing house;*
- c. *The extension does not adversely affect the privacy or amenity of neighbouring properties;*
- d. *The visual impact of the extension from the public spaces or*

parking courts must be substantially reduced by the rear boundary wall of the property, which may require heightening to achieve this (subject to the effect on neighbouring properties or group).

2.05 Conservatories are widely marketed as home extensions. The plain timber and glass greenhouse has been superseded by elaborate constructions with angled forms and elaborate detailing, often a pastiche Victorian style. While timber conservatories remain available, many are also constructed in UPVC and can be found in 'do it yourself' warehouses in kit form for self-construction. It is considered that there will be comparatively few properties where conservatories will be an acceptable form of extension. They will be subject to the same criteria of acceptability as extensions generally and must be:

- a. *Of modest size in relation to the ground floor of the house;*
- b. *Not unduly complex in plan, or elevation (tall conservatories with pent roofs are not acceptable);*
- c. *Of simple design, with windows and other elements of good proportion, to complement the existing house (elaborate Victorian reproductions are not acceptable);*
- d. *Of timber construction (UPVC is not considered to be a sustainable material within the meaning of the Design Manual);*
- e. *Capable of substantial concealment by the property boundary wall which may be raised (subject to impact on neighbouring properties or the group - this will also apply to conservatories at the side of houses as well as at the rear).*



Example of how extension should address the street, Poundbury, Dorset



Example of a well designed conservatory



Example of how a conservatory should be hidden from the public
Adam Architecture



Design for a high quality discreet conservatory
Adam Architecture

3.00 Building Materials and Details

3.01 Nansledan was designed to use high quality, natural materials, with detailing to reflect the regional Cornish vernacular styles, allied to traditional construction methods. Every attempt was made to achieve consistently high standards to match those found in the historic towns and villages of the county and recapture delight in design. However, it is accepted that some materials, including timber, have not shown the lasting qualities found 100-200 years ago. When building work, including replacement and extension is under consideration, owners will be expected to:

- Repair rather than replace original windows and doors;
- Use replicas for small extensions;
- Build walls in matching brick, stone, slate hanging or rendering;
- Roof in matching slates, tiles or corrugated sheeting.

Nansledan contains numerous examples of simple designs, enlivened by the attention given to the treatment of roof eaves, dormer windows, windows, doors and porches. Anyone contemplating works should study their own property as well as the way details and materials are handled in comparable situations elsewhere in the development. Owing to the variety of treatment, the comments in the following sections may not cover all individual situations. If in doubt, ask the Duchy office before finalising your proposals.



Callywith stone with brick quoining



Yennadon stone with brick quoins



Granite is used for lintels and landscaping. Slate is used for cills and roofs.

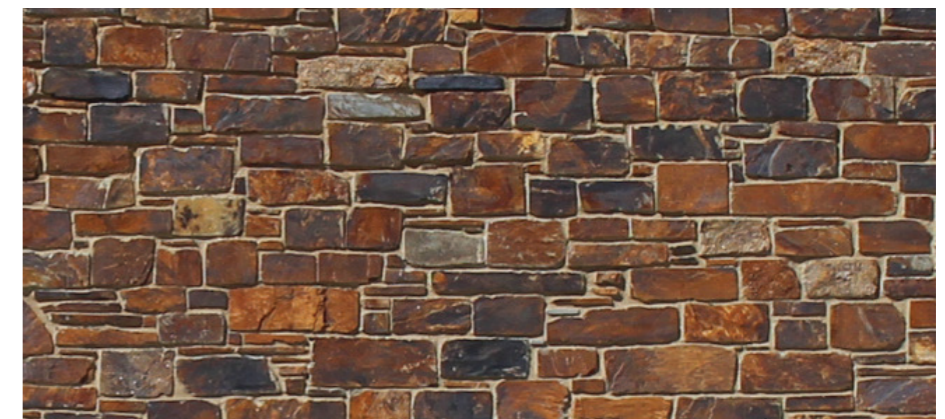

High quality sawn stone wall with appropriate mortar colour and pointing profile to reveal full colour and texture of the stone

4.00 External Walls

4.01 The palette of walling materials gives Nansledan a visual variety, within the overall unity of the local vernacular tradition. Extensions and alterations should enhance not detract from the character. The following materials are acceptable under the Design Manual:

STONE

- Preference should be given to sourcing stone within Cornwall.
Stone can be ashlar, sawn, rubble or slate hanging to match existing. Walls must have an outer skin of at least 100mm thick to allow for larger stones to be built-in. All stone work must be designed to give the appearance of load-bearing, even if additional hidden structural support is provided.

Particular attention must be given to coursing and pointing, laying stonework in the traditional manner and avoiding 'ribboned' or struck mortar which stands proud of the stonework, or recessed pointing – the face of the wall should appear reasonably flat.

Stone work and render can only be mixed where these different materials are applied to distinct elements of the building.
- Reconstituted stone may only be used where agreed with the Duchy.

4.00 External Walls



Hung slate detail



Hung slate building



Painted brick building

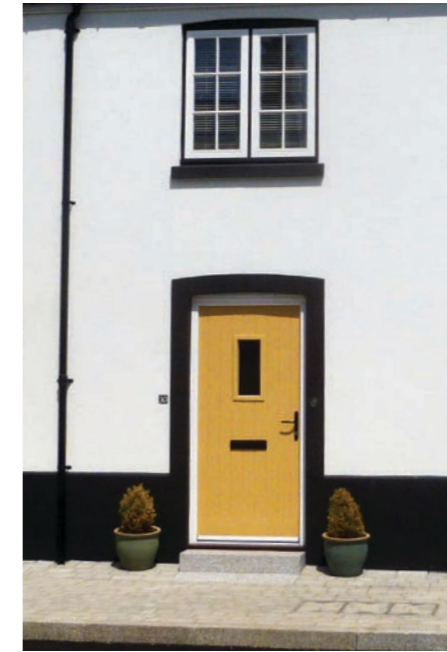

Render building



Rough cast render building

SLATE HANGING

- a. All slate must be local Cornish Slate and preferably smaller gauge, unless otherwise agreed by the Duchy of Cornwall.

TIMBER

- a. Buildings may be clad with weatherboarding and painted with traditional paint or black tar varnish.
- b. Paint colours must be approved by the Duchy. A selection of pre-approved external colours is available in Appendix E.
- c. Weatherboard may be used in parking courts and mews streets, as well as on outbuildings.



Painted timber building

BRICKS

- a. Bricks shall be buff, handmade, or stock facing brick to agreed with the Duchy. Harsh reds and wire cut or dragged bricks shall not be used. If extending a painted brick building, it is likely that the extension should be finished in a similar way.
- b. Bricks should be laid in English or Flemish bond. Variants such as Garden Wall bond will be considered where appropriate.
- c. Where half brick facing is used in cavity construction, purpose made snap headers or mechanically cut bricks must be used. Special bricks are required at odd angle corners. Cut bricks will not be acceptable where the cut face of the brick is left exposed or the perpend joint appears on the arris of the corner.
- d. Stretcher bond is not permitted.
- e. Where agreed, painted bricks can be used. Colours must be approved by the Duchy. A selection of pre-approved external colours is available in Appendix E.

RENDER

- a. Render can be applied to stone, brick, cob, hempcrete, clay block, dense concrete block and timber backgrounds.
- b. Rendered work should give the appearance of a thrown render. External corners should be formed in render by hand, not using metal stops.
- c. Bell drop moulding should not be used.
- d. Render shall match existing in terms of material, texture, finish and colour to avoid a patchy appearance. Where the nature of the existing material is not known, this should be verified through analysis. Renders and paints for rendered walls are to be of types and colours agreed by the Duchy.
- e. Paint colours must be approved by the Duchy. A selection of pre-approved external colours is available in Appendix E.

4.00 External Walls

MORTAR

- Lime rich mortars must be used. Cold, grey cement-rich mortar joints will not be acceptable.
- All mortar joints must be tamped with a stiff bristle brush or struck with a stick before they set to expose the aggregate.

For stonework:

- Different stones require different mortar mixes. The appropriate mortar must be carefully chosen so that the colour of the stone aggregate tones with the colour of the stone.
- Mortar joints must be kept thin; between 5mm and 10mm for ashlar and no more than 20mm for rubble stone. Sawn stone must have flush joints.

For brickwork:

- Mortar shall generally be 1:2:9 white or ordinary Portland cement white lime: washed sand. The silica alumina content of the mortar should not exceed 12% to avoid excessive hardness. Joints should be flush or concave as work proceeds. Mortar joints should not be weather struck, raked or ribbon. Penny struck joints might be used on the more important buildings. Mortar joints shall be 10mm maximum, to match existing.

LINTELS

- Wherever possible lintels should be true load-bearing constructions in granite, brick, flat tiles or timber. Where brick or stone are used, lintels shall be formed as true arches. Rubbed brick lintels are appropriate only on more important buildings. Rough arches in various forms (particularly the 'justified' rough arch) are suitable in brickwork and should rise through four brick courses. In stone construction, voussoirs should be provided. Soldier arches (flat arches with brick upright) are not allowed.
- Timber (oak) lintels typically 150mm deep, with minimum 215mm bearing on either side of the opening, may be used. Use should be made of relieving arches in masonry above timber lintels where loadings dictate.
- In instances where true load-bearing lintels cannot be achieved and steel lintels are required, these must not be left visible.



Hardwood timber lintel



Segmented brick arch



Granite monolith lintel

COPINGS

- Care should be taken to ensure copings on gables or parapets are neither too thin or too thick. On raised gables on smaller buildings, the visible edges or copings should typically be less than 75mm thick. Parapet copings show an edge of about 75mm thick. Copings, generally, should not extend more than 25mm from the plane of the wall beneath.

PARTY WALLS

- Party walls rising above the roof and raised or parapeted gable should be no less than 215mm thick.

CONTROL AND EXPANSION JOINTS

- Control or expansion joints in brickwork or render will only be permitted where these can be detailed so as to be invisible on public realm facing elevations, such as through changes in material, or paint colour, behind rainwater downpipes and at steps in the building line. Visible control and expansion joints on public realm facing elevations will only be permitted where agreed in advance by the Duchy.
- Any situations where it is not possible to hide expansion joints need to be discussed with the Duchy of Cornwall at an early stage and special dispensation received. The default position is that no expansion joints should be visible on public realm facing elevations.

AIRBRICKS AND WEEPHOLES

- Where airbricks are essential to satisfy Building Regulations, these shall be of terracotta, built tile, painted cast or unpainted drilled stone.
- Wherever possible, weepholes over window and door openings are to be visually minimised. Weepholes at this level should be formed using straw vents.

4.00 External Walls

DOORS AND PORCHES

All doors have been designed to be in character with the properties to which they relate. There will be a presumption in favour of repairing, rather than replacing existing doors. This is particularly important where grouped houses are involved, with a uniform overall elevation. The replacement of even a single door, by an unsuitable or over elaborate modern type, could mar the harmony of a group or street scene. Where extensions are involved, the door should match or be in harmony with the existing, particularly when publicly visible.

- a. External doors shall be single or double and of a pattern approved by the Duchy. Door patterns will only be allowed as true imitations in form, construction and proportion. This equally applies to fanlights.
- b. Doors should be painted and should complement the colour of the building and window frames. Varnished hardwood doors will not be allowed, even if authentically constructed. Colours must be approved by the Duchy. A selection of pre-approved external colours is available in Appendix E.
- c. Moulded or pressed metal doors will be permitted of a pattern approved by the Duchy. Moulded or pressed UPVC doors will not be permitted.
- d. Ironmongery shall be solid brass, bronze or black iron of a type appropriate to the style of the door and house. Plastic and chrome numerals, letterboxes and knockers will not be permitted.
- e. Doors may have glazed upper panels. Patterned reproduction leaded lights, plain or with coloured glass, adhesive films or other attempts to further obscure the glass, internally or externally, will not be permitted without prior approval by the Duchy.



A simple door with rough brick arch and quoins.



A simple door with appropriate use of contrasting colours.



A well-proportioned six panel door with lights above.



A four panel door with glazed upper panels.

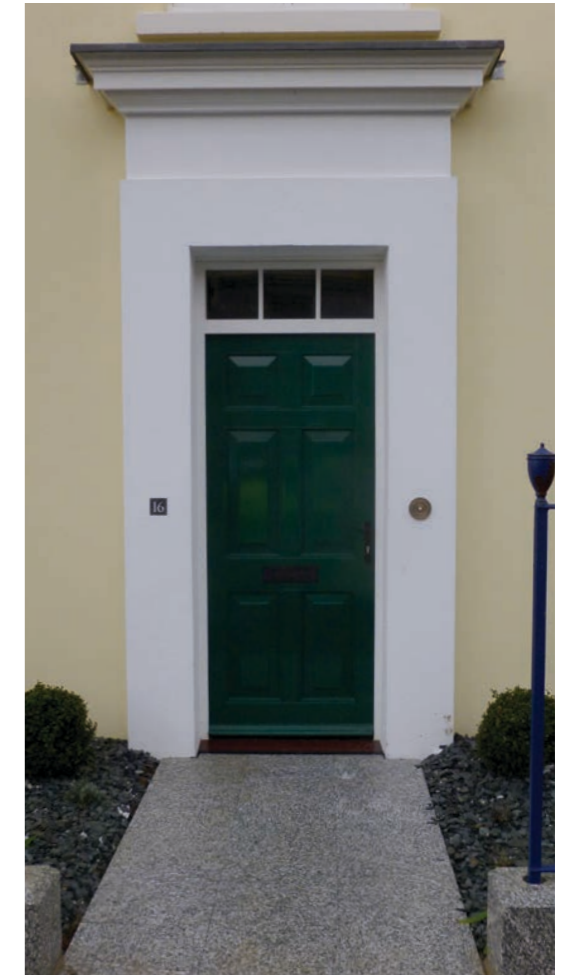

A well-proportioned six panel door with lights above.

4.00 External Walls

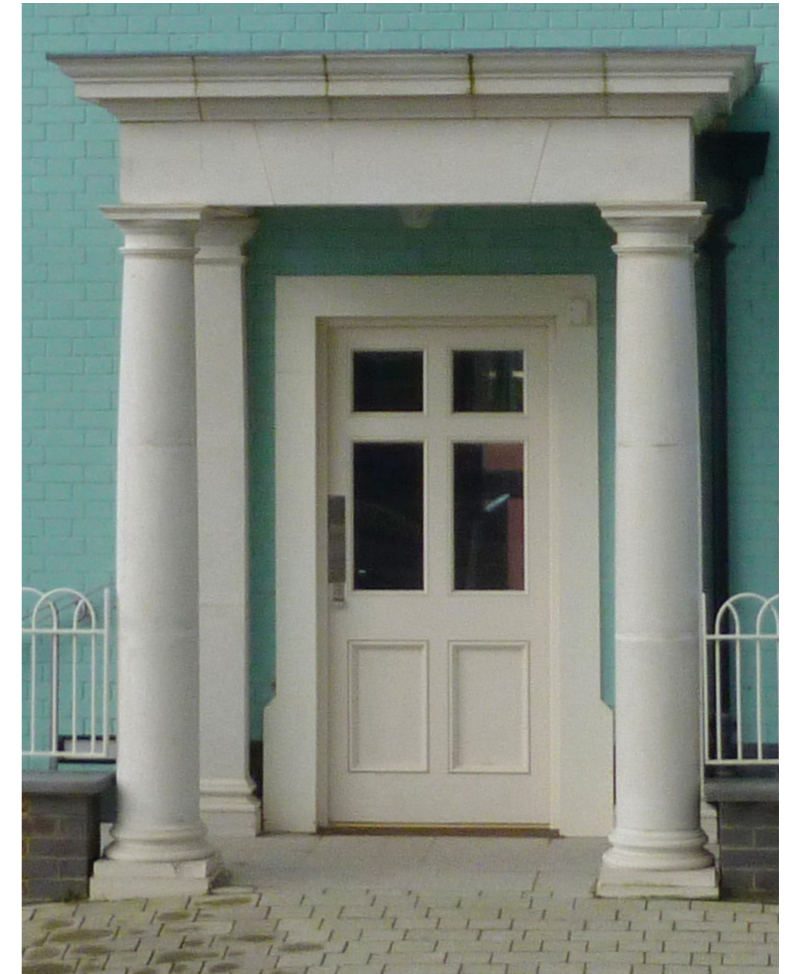

Porches and door surrounds have been designed as integral elements in each existing building and group. There will be a presumption in favour of retaining the existing, unless it can be conclusively demonstrated that a variation would enhance the building concerned, without disrupting the group or townscape harmony. The guidance on porches is also applicable to verandas and loggias.

a. The design of porches must reflect the scale and importance of the building. The addition of enclosed front porches to existing buildings will not be allowed.

b. Projecting porches or door surrounds shall not, unless specifically permitted, extend into the pavements zone and must be of an appropriate traditional design.

c. Columns, posts, piers and brackets shall be of timber, stone, brick or cast iron.

d. Classical door surrounds must be authentically proportioned and literate.

e. Fabricated and kit porches and door surrounds are not allowed, nor

are pre-formed fibreglass, Georgian door surrounds. Stained timber or uPVC glazed porches are not permitted.

f. When painted, porches should generally match the paint finish of the buildings windows and complement the colour chosen for the front door. Classical porches should be painted white or a suitable pale stone colour. Colours must be approved by the Duchy. A selection of pre-approved external colours is available in Appendix E.

4.00 External Walls

WINDOWS

The overall size and shape, relation of void to solid, their subdivision, including the pane size, and proportion, relating to glazing bars, is critical to the success of the overall design and appearance of the building. The original buildings were designed with harmonious proportions, particularly the more formal landmark houses. There will be a presumption in favour of repairing rather than replacing existing windows. If replacement is necessary, then a replica of the existing window will be required. The replacement of even a single window, by an unsuitable type, could mar an entire group or street character. Where extensions are involved, the windows should match, or be in harmony with the existing, particularly when publicly visible.

- a) Windows shall be of a rise and fall sash or side hung casement type. All casement windows on the ground floor, when fully open, should remain within the private margin and should not open beyond this margin into the adoptable area.
- b) Bay windows should be habitable spaces carried to the ground. Oriel windows are a feature of some seaside buildings and may be acceptable when appropriate to the overall design context and layout.

- c) Windows must reflect the overall scale, proportions and design of the building.
- d) In new extensions, alterations or when replacing windows, they should be constructed of timber from sustainable sources. Tropical hardwoods are not allowed. Slim section metal framed windows will only be permitted where accepted by the Duchy. Stained timber, UPVC, or plastic coated timber frames will not be permitted.
- e) All windows, as a minimum, should to be double-glazed either with sealed units or by secondary glazing. French doors and window panes below 800 mm above floor level are to be provided with laminated safety glass.
- f) There is a presumption in favour of windows to bathrooms not facing the street. They should not have obscured or patterned glass. All glass should be clear. Patterned reproduction leaded lights, plain or with coloured glass, will not be permitted.
- g) When used, glazing bars in sash windows should create panes that are vertical in emphasis and follow the traditional 4,9,12 or 16 pane pattern, All panes must be the same size and proportion on an elevation.

- h) Windows on upper floors must be either equal or smaller than windows on the ground floor.
- i) Pivot windows and windows with asymmetrical subdivision will not be permitted. Windows with 'clip-on' or applied glazing bars should be avoided where possible. Where used, integral spacers in the double glazing unit are to be incorporated in the colour to match the window frame.
- j) Windows should generally be set back at least 50mm from the building face, creating a shadow line and a sense of solidity. On slate hung buildings, windows can be flush with the facade.
- k) Windows shall be placed no closer than 750 mm to the centre line of the nearest party wall or to a corner of the building.
- l) Windows shall generally be painted white or off white but some can be white painted casements with back or coloured window frames. A range of suitable colours may be specified by the Duchy. Colours must be approved by the Duchy. A selection of pre-approved external colours is available in Appendix E.



Oriel window



Bay window



Traditional Cornish black & white painted window

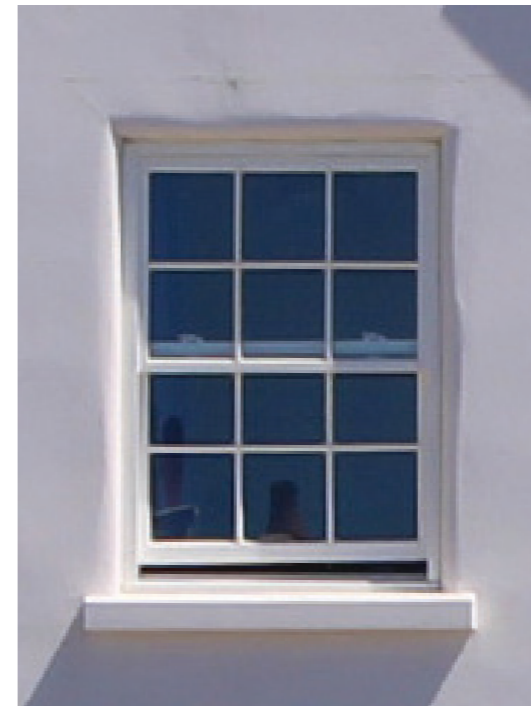

Rise and fall sash window.



Side hung casement, granite lintel and slate cill.

5.00 Roofs and Chimneys

5.1 Cornish roofs are characterised by a limited palette of materials, simple forms and details. These are essential features of the townscape of Nansledan. Alterations and extensions should complement this richness and not obtrude with inappropriate detailing or materials. The palette should be limited to materials that are traditional to Cornwall. The Design Manual requires the following:

- a. Roofs should be simple and symmetrical, gabled or hipped. Abutting single storey roofs may be lean-to. Complex and overworked roofs will not be permitted. Free-standing sheds, garages or outbuildings shall have gabled or hipped roofs. Flat roofs will only be permitted where approved by the Duchy. Where appropriate, the use of dormers can add interest and character to the roofscape.
- b. Roof coverings shall be natural slate to match existing with attention paid to the existing grading of the slates. Preference shall be given to sourcing slate from within Cornwall. Reconstituted or cement fibre slates are not permitted. Corrugated sheet may be permitted on outbuildings. Clay roofing tiles are

not characteristic of the area and their use is therefore limited and may only be used where agreed with the Duchy. Ridge vents and tile vents are not permitted. Concrete plain tiles or concrete interlocking tiles are not permitted. Correctly detailed lead flat roofs to dormers may be acceptable.

- c. Roof pitches will vary according to the type of roof covering from a minimum of 30 degrees up to 55 degrees. Pitches of 45 degrees should be avoided. All subservient roofs must be of equal or lower pitch than the main roof.
- d. Eaves at Nansledan generally must be simple in design and not overly decorative unless merited by the design of the building on a main street in a prominent position. Decorative eaves, cornice, open rafter or bracketed eaves will only be permitted on the larger, more prominent buildings to primary and secondary streets. Boxed fascias and soffits will not be permitted.

Where buildings have decorative eaves, and where the gutter forms an integral part of that detail, the gutter should be ogee in profile and colour matched, together with the downpipe and all

associated fittings, to the colour of the decorative eaves detail so that it reads visually as an integrated design.

- e. Verges generally will be simple with the wall finish taken up to the underside of the roof covering. Slates or tiles should project between 30-50 mm. Slate verges may be used where appropriate. Barge boards may only be used on prominent gables where they are appropriate to the style of the building. They will have simple mouldings, or occasionally may have fretwork or decorative mouldings. If used, they must comply with the Design Manual.
- f. Ridges shall be finished with either angled, half round or hogback clay ridge tiles. Where used with slate roofing these shall be black or terracotta. Where used with clay tiles they should be the same colour as the main roof.
- g. Hips will generally be finished with clay tiles of similar colour and profile as the ridge. Mitred hips and lead roll hips will be permitted on slate roofs.
- h. Valleys to slate roofs will be constructed of lead. To clay tile roofs valleys may be constructed of either lead or clay valley tiles.



Bracketed eaves



Cornice eaves



Local Cornish Slate



Close Clipped eaves

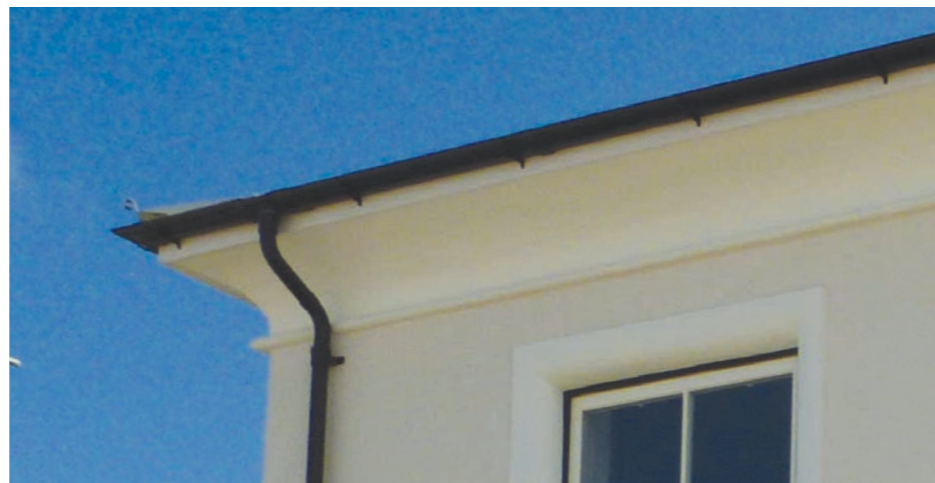

Cornice eaves



Slate Verges



Simple Verge with wall finish taken up to underside of roof

5.00 Roofs and Chimneys

DORMERS

Dormers are common features on many buildings across Cornwall, mostly on smaller cottages and farmhouse buildings. In considering whether dormers are acceptable, the degree of additional overlooking will be assessed by the Duchy.

- Dormers should be carefully designed and built to suit the roof they sit within and materials used. They must be of such a size and scale that they do not dominate the form of the roof.
- Dormers must be built of timber and can be slate hung, clad in lead, aluminium or rendered. The cheeks may incorporate window panes. The roofing material must either replicate the material of the main roof or be lead, copper or scantle slate. Clay tile can also be used as a roofing material, but only sparingly in the street scene. The use of 'fibreglass replicas' will not be an acceptable alternative.
- Where used, flat roof dormers must be clad in lead or copper with painted timber profile cornices at eaves.
- Needless hip bulkiness should be avoided by using mitred slate or lead roll hips on slate clad hipped dormers. If the dormer roof is gabled rather than hipped, the verge should be made disproportionately deep, perhaps 75 or 100mm, to give a deeper shadow with the slate or tile batten running past the line of the gable end.



Good example of a half dormer with clipped eaves

- Dormer windows with window frames taller than 600mm will be vertical in format. Dormer windows individually or collectively will occupy no more than 40% of the total horizontal dimension of any roof plane.

ROOF LIGHTS

Rooflights are not common in Cornwall.

- Small traditional 'conservation type' rooflights may be acceptable in inconspicuous situations, but not on front or visually prominent roof slopes, particularly where they might disrupt a group or design, or create an unfortunate precedent. Modern rooflights, in deep frames, which break up the line of the roof plane are not acceptable.
- When rooflights are permitted, when joining dormer windows to the existing roof, or weathering new parapets, the appropriate weight of lead should be used. Correct detailing should be used, to tuck valley flashings and soakers beneath the adjacent slate or tile margins, which should be raised on battens to enable this. Modern lead composition or substitute materials are not acceptable for flashings.



Good example of dormer window with cornice

RAINWATER GOODS, GUTTERS AND PLUMBING

- Rainwater goods should generally be powder coated or anodized aluminium painted black, white, cream or classic dark tones as approved by the Duchy. Gutters shall generally be half round or ogee profile. Hopper boxes on fronts of parapeted houses shall be aluminium. Plastics and UPVC are not acceptable.
- Where there are no gutters, there shall be provided, at the foot of external building walls, a French or perforated drain, set in a ground bed, approximately 600mm.
- Flue terminals and extract ventilation terminals will not be permitted in walling or roofs on front elevations, or elevations facing the public realm.
- Vent stacks may be enclosed within chimneys where it does not conflict with a class 1 flue. Where this is not practical, vent pipes should be clad in lead where they emerge above roof slopes or should be terminated within the roof space by an air admittance valve wherever acceptable to Building Control officers of Cornwall Council.



Conservation type of rooflight flush with the roof



Traditional brick chimneys with clay pots and a rendered chimney with slate pot



Chimney shoulder

CHIMNEYS

Virtually every house has been designed to incorporate at least one chimney. A chimney is integral to the characteristic traditional silhouette of Cornish architecture, without which a new development descends into being a banal housing estate. The Design Manual requires that:

Chimneys should be faced with brick or stone, complementing the façade finish. Rendered chimneys are discouraged due to the ongoing maintenance required, however may be acceptable in limited quantities where the chimney is flush with and forms a continuation of the buildings side elevation. Chimneys shall be finished with a corbelled detail at the top and a traditional slate or terracotta pot.

The size of chimneys should be proportionate with the size of the house. Smaller houses should generally have short and squat chimneys with a simple corbel and pot. On grander and larger homes, chimneys should rise generously above the roof and be approximately twice as deep as they are wide. Chimneys on smaller houses should be smaller in scale, less elaborate in detail and use smaller pots. Bigger buildings should have bigger and more elaborate chimneys and, if there is a pot, it should be larger and in keeping with the overall design.

Chimneys should usually be placed on the gable-end of buildings unless a terrace where it should be located on the party wall.

Chimney stacks may be used to disguise a ventilation system within.

All existing chimneys were designed with appropriate construction. Permission will not be given to demolish chimneys. If a comprehensive repair should be necessary, then a replica of the existing chimney must be built, complete with corbels and over sailing courses, and pots to match.

6.00 Outbuildings

- a. Outbuildings may be timber framed and clad with weather-boarding. Traditionally, however, the buildings of less important dwellings are frequently built of whatever comes to hand and may show a charming variety of materials. Proposals will be assessed on their effect on the context of the building to which they relate, and the overall group.
- b. Weatherboard cladding should comprise feather-edged boards approximately 175 mm x 32 mm. Generally, feather edged boarding should be sawn finished with a plain edge or beaded on the lower edge of planed boards, all finished with Sadolin Beautiflex. Shiplap boarding is not permitted. Colours must be approved by the Duchy. A selection of pre-approved external colours is available in Appendix E.

7.00 Boundary Walls, Fences and Gardens

BOUNDARY TREATMENT

The treatment of boundaries between individual properties, and between public and private realms, is not an afterthought, but is integral to the overall design of Nansledan. The Design Manual sets out a hierarchy for boundary treatments as they relate to the public realm. Boundary treatments and gates may not be altered without prior consent from the Duchy.

PRIVATE GARDENS

- a. Pathways, visible from the street shall be gravel, cobbles, stone or brick construction. Pathways adjoining the public, but not visible from the street, may additionally be soft landscaped with planting on soil pockets.
- b. Existing trees have been planted to complement the urban character of buildings and enclosed public and private outdoor spaces. Additional planting of appropriate indigenous species should be preceded by arboriculture advice on height, rate of growth, spread of canopy and roots. Hedges should be of an appropriate indigenous species, as listed in the Pattern Book and Green Infrastructure Strategy, and be trimmed regularly to avoid loss of light to neighbouring properties. Cupressus Leylandii, or similar, fast growing species, are not appropriate.

8.00 Ancillary Elements

Small features added to a building or placed within gardens, can, if done without sufficient care or attention, mar the appearance of the building or its setting. Good design or unobtrusive siting can often overcome problems.

a. The following items are specifically forbidden:

Bubble skylights, prefabricated accessory buildings, permanent plastic sunblind/awnings, plastic commercial fascias and lettering and internally illuminated fascias and signs.

b. The following items shall not be located such that they will be visible from the street:

Clothes dryers, meter boxes, air extractors, dust bins, rooftop solar collectors.

c. No waste or soil pipes may be attached to the exterior of any house. Combined internal systems of drainage are to be used.

d. The scheme is to be designed to have the benefit of fibre optic broadband, as well as a central satellite system, so that no television aerials or satellite dishes will be necessary. External individual television aerials and satellite dishes are not permitted.

e. External house lights on street elevations, other than those provided, are not permitted.

LETTERING

House numbers and street names are consistent in position and design so that they are readily identifiable, particularly by emergency services. They are the responsibility of the Duchy of Cornwall and home owners will be required to conform with the Lettering Guidelines set out in Appendix C.

9.00 Business Premises

Nansledan is designed as a living and working community on the edge of Newquay. Business uses intermingle commercial activity with the predominantly residential buildings of Nansledan. This principle is fundamental to the planning of the community. Today, and increasingly in the future, the culture of enterprise will often begin in the home, with moves to purpose-designed units or shops as business expands. The design and servicing of houses recognises the increasing demands for flexible living arrangements and working from home. However, this does not mean that the Duchy will permit a free for all. Working from home is only acceptable as long as the domestic character of the property is not compromised.

a. Working from home requires permission from the Duchy. Applications must demonstrate that this activity is, and will remain, ancillary and subsidiary to the domestic use of the property as a residence.

b. No business plates or signs will be permitted on residential properties.

c. The lessees and occupiers of all business premises and shops are subject to the same controls as are those of residential properties. The design of shopfronts and business signs is strictly controlled, and is subject to the observation of the principles set out in Appendix D.

10.00 Accessibility

The Design Manual is sensitive to the needs of accessibility for all houses, so that they are capable of adaptation to suit the physical needs of people with impaired mobility and wheelchair users, including visitors. It is possible that elements of the adaptation may be undertaken by householders, or that they may wish to add an extension to meet the specific needs of, for example, an elderly relative. All adaptations require the consent of the Duchy, and will be dealt with on a case by case basis.

11.00 Environmental Issues

A building which looks well may still be environmentally unfriendly in other respects, for instance in the material it is made of or in its profligate energy consumption. The Design Manual describes the method which is used to assess the environmental consequences of building design. It is also applicable to alterations and extensions. These may also require approval of the Cornwall Council, under the Building Regulations, particularly if alteration to the thermal fabric or drainage is involved.

12.00 Utilities

Nansledan front elevations are designed to be free from unnecessary clutter, as such most utility meters are on the rear or side elevations. To facilitate this, utilities are generally run to the house from the rear courtyard or are run under the house to connect at the back. In some cases, these connections and service runs may conflict with a proposed addition. A plan with the indicated service runs for each property can be obtained from the Management Company for the appropriate area. Do not excavate your garden without first checking with the management company and acquiring consent.

13.00 Cornish Language

Nansledan reflects the culture and heritage of Cornwall not just through its architecture and materials, but also through its place names. Nansledan itself is Cornish for 'broad valley' and thanks to the help of MAGA, the Cornish Language Partnership, every street, lane, square and quarter in Nansledan has a Cornish name.

There are two main sources for the names within Nansledan. The first is using names from the Arthurian legends as recorded in Sir Thomas Malory's *Le Morte D'Arthur*, wherein the events of King Arthur and his round table took place locally. The Arthurian names have been supplemented by local field and place names suggested by local people or drawn from archive records.

14.00 Bird, Bat, Bee and Other Habitats

Bat, bird and bee habitat is incorporated into the outer structure of buildings throughout Nansledan as a component of the Ecology Strategy for Nansledan.

Bat and bird nesting boxes are commonly located in or just below the eaves. They are designed to encourage roosting for bats, swifts, house sparrows and swallows.

Bee hotels are incorporated into brick and render houses in the shape of a standard brick. These are designed to encourage solitary bees, such as the red mason and leaf cutter, which are non-aggressive species. In return for habitat they reward us with pollination of our trees and plants.

It is prohibited to tamper with the bat, bird and bee habitat. If a resident has a concern about one of them, contact the management company directly.

Gardens need to incorporate 150mm x 150mm gaps at wall/fence bases to ensure hedgehogs can move through the site post development.



Bee bricks courtesy of Green & Blue



Examples of two types of bird boxes



Malus D. Cox's Orange Pippin



Prunus D. Czar

15.00 Edible Planting

One of the Original Strategy Documents for Nansledan specifically sets out a Food Strategy. The aim is “to encourage measures that will improve the sustainability of food in the Newquay area and help reduce diet-related ill health, reduce environmental damage and promote local economic regeneration, employment, tourism, skills and long-term support for local food producers”. The realisation of this takes many forms across Nansledan, but it can be seen in a practical sense in the form of edible planting.

Espaliered fruit and nut bearing trees are primarily located in parking courts or other public spaces. These are under the management of the local management company, but all are welcome to the produce. It is prohibited to remove any of these trees. If a resident has a concern about one of them, contact the management company directly.

A scheme of edible herbs and plants was set out for each front garden in Nansledan. Residents are encouraged to engage in the food strategy by fostering and maintaining these plants.

16.00 Making your Application

Estate Stipulations reproduced at Appendix A form part of the legal title to each property and are binding on freeholders and tenants.

Certain restrictions within the Estate Stipulations provide for the Duchy's prior approval to be obtained particularly the plans and specifications of any external alterations or additions, particularly of windows, glazing and doors, or to alter or change the appearance. Consent is required to paint or decorate the exterior of a building, otherwise than the same colour as previously. It is also required for painting render, brickwork or stonework, when there will be a presumption in favour of retaining the original appearance of the natural state.

In making an application for any matter requiring approval or consent, it is vital to present a clear and accurate picture of what exists and what is proposed. The level of documentation will be related to the extent of what is proposed. Drawings must be to scale with sufficient detail to show the proposals in context, particularly where a group of

buildings is involved, photographs may be helpful. To show the overall property, plans and elevations should be submitted to a scale not less than 1:100, ideally 1:50. For particular features, for example dormer windows, a scale of 1:20 will be required. In some circumstances, details such as mouldings may require full size drawings prior to the granting of approval.

Applications will be considered by the Duchy. The policies and criteria set out in this guide will be taken into consideration, and the merits of each application will be assessed carefully against these.

For proposals that would normally require planning permission, it is not necessary to apply for planning consent from Cornwall Council provided that such proposals comply with the Nansledan Local Development Order (2021) and that a Certificate of Conformity has been issued by the Duchy of Cornwall prior to the commencement of works.

The Duchy may consult neighbours or occupiers of other properties likely to be affected and will consider their views. Some proposals may possibly require amendment before they can be approved. In cases of refusal, the reasons for reaching the decision will be explained. The Duchy may require payment of a fee.

Informal discussion, prior to making an application will be welcomed, and may be helpful in fine-tuning a concept before it attains its final form. Applications should be submitted to:

Nansledan Estate Office
Trewollack Farmhouse
Newquay
TR8 4PB
E-mail: Nansledan@duchyofcornwall.org

APPENDIX A

ESTATE STIPULATIONS

17.01.23

Appendix A - Estate Stipulations

1. To comply with the Design and Community Code and the Design Manual in respect of the Unit.
 - 2.1 Not:
 - 2.1.1 to make any alterations or additions in or to the exterior of the Unit (including the windows the window glazing and the doors);
 - 2.1.2 to alter the external appearance of the Unit;
 - 2.1.3 to paint (unless already painted) or remove the render brickwork or stonework of the exterior of the Unit;
 - 2.1.4 to build upon any garden yard forecourt or open area forming part of the Unit;
 - 2.1.5 to lay artificial grass upon or over any garden yard forecourt or open area forming part of the Unit that is in the public realm (where not in the public realm, the laying of artificial grass is discouraged); or
 - 2.1.6 to alter the general appearance of and not to pave over any garden yard forecourt or other external open area (unless already paved over) forming part of the Unit,

without His Royal Highness's prior consent provided that His Royal Highness may refuse consent to any matter which is not consistent with or is in breach of the Design and Community Code or the Design Manual.

If commenced, to carry out any matters approved under Paragraph 2.1 in accordance with the Design and Community Code; the Design Manual and
 - 2.2 any drawings plans and specifications approved by His Royal Highness
 - 2.3 To give to His Royal Highness:
 - 2.3.1 notice of any application for planning permission made by the Owner or (if the Owner is aware of the same) any other person in relation to the Unit; and
 - 2.3.2 a copy of the application and all drawings plans and specifications in relation to an application by or on behalf of the Owner.
- 3.1 At all times well and substantially to repair paint and cleanse the exterior of the Unit so that it shall (subject to any alterations approved in accordance with the Estate Stipulations) as far as practicable retain an appearance and colour similar to that at the date of the initial transfer or lease of the Unit.
- 3.2 Not without the prior consent of His Royal Highness to decorate or paint the exterior of the Unit otherwise than in the same colours as the Unit was previously painted.
- 3.3
 - 3.3.1 To maintain and when necessary replace all boundary walls fences and hedges where marked "T" within the boundaries of the Unit.
 - 3.3.2 Not to raise the height of any boundary walls fences and hedges.
 - 3.3.3 Not to build any wall fence or other structure or erection on the part of the Unit edged orange on the Plan (if any).
- 3.4 Any reinstatement of any damage or destruction of the Unit shall be to its original condition or if changed in accordance with the Estate Stipulations its condition prior to such damage or destruction.
- 4.1 (Residential Units only)
 - 4.1.1 Not to use the Unit for the carrying on of any trade or business subject to Paragraph 4.1.2.
 - 4.1.2 To use the Unit as a single private dwelling for the occupation of one household save that the Unit may be used for business purposes (including home-working) on the following terms:
 - (a) the business use must be ancillary to the principal use of the Unit as a single private dwelling;
 - (b) the prior consent of His Royal Highness must be obtained save in respect of home-working;
 - (c) the business use must be capable of being carried out in accordance with the principles of the Estate without detriment to the amenity of the Estate by reason of noise nuisance or otherwise; and
 - (d) the appearance of the Unit as a single private dwelling must not be affected or altered.
- 4.2 (Commercial Units only)

Not to use the Unit other than as a commercial Unit for use within Use Class B2 B8 C1 C2 E F1 and/or F2 of the Town and Country Planning (Use Classes) Order 1987 (as amended by the Town and Country Planning (Use Classes) (Amendment) (England) Regulations 2020) without the prior consent of His Royal Highness.

 5.
 - 5.1 Not to do or permit to be done in or upon the Unit anything which may be or become a nuisance annoyance or inconvenience or cause damage or loss to His Royal Highness or the owner or occupier of any other part of the Estate.
 - 5.2 Not to allow on the Unit the emission or production of any recorded or broadcast sound so as to be audible outside the Unit.
 - 6.1 Not to mutilate or remove any trees or shrubs which may be planted within the Unit.
 - 6.2 Not to plant any trees or shrubs within the Unit other than in a location approved by His Royal Highness.
 - 6.3 Not to relocate any trees or shrubs within the Unit other than in a location approved by His Royal Highness.
 - 6.4 To maintain lop top prune and cut any trees or shrubs within the Unit as may be necessary to preserve the amenity of the Estate.
 - 6.5 Not to lay artificial grass upon or over any garden yard forecourt or open area forming part of the Unit.
7. Not to put any sign advertisement notice plate placard hoarding or flag of any kind in any window of the Unit or on the exterior of the Unit or so as to be visible from the outside of the Unit other than:
 - 7.1 the existing building number;
 - 7.2 the name of the Unit on a sign of a size and in a position first approved by His Royal Highness;
 - 7.3 one board of a reasonable size advertising that the Unit is for sale or to let; and

- 7.4 (Commercial Units only) signs indicating the name of the business being undertaken at the Unit such signs to be of a type and size and in a position first approved by His Royal Highness.
8. Not to expose any washing or clothes on or from any front elevation or front garden of the Unit.
- 9.1 Not to keep any bird, dog or other animal on or in the Unit other than the usual domestic pets;
- 9.2 Not to keep or permit to be kept on the Unit any bird dog or other animal which may cause annoyance to any owner or occupier of any other part of the Estate or to the general public
- 9.3 Not to permit any dog or other animal to foul any land comprising a Special Area of Conservation or any other equivalently designated area
10. Not to obstruct or permit to be obstructed the Public Domain including any common roadways pathways courtyards or other communal areas within the Estate.
- 11.1 (Residential Units Only) Not to park or permit to be parked on any parking space (including a standard off-highway parking space) any vehicle other than a private motor vehicle or a permitted commercial motor vehicle (being a commercial motor vehicle which is capable of fitting into the parking space with regard to the wheelbase and the body of the vehicle).
- 11.2 (Commercial Units Only) Not to park or permit to be parked on any parking space (including a standard off-highway parking space) any vehicle other than a private motor vehicle or a permitted commercial motor vehicle (being a commercial motor vehicle capable of fitting into the parking space with regard to the wheelbase and the body of the vehicle).
- 11.3 Not to permit any trailer towing-caravan boat or other similar thing (including anything that is incapable of self-propulsion) to be brought onto the Unit or to be parked in any parking space within the Unit or any communal area or on a highway.
- 11.4 To use any parking space within the Unit as permitted under Paragraph 11.1 or 11.2 for parking a private motor vehicle or permitted commercial motor vehicle in priority to any parking space in a communal area or on a highway.
- 11.5 Not to park any private motor vehicle or permitted commercial motor vehicle on any parking space in a communal area (including a standard off-highway parking space) or on a highway if no motor vehicle is parked on any parking space within the Unit.
- 11.6 Not to park any motor vehicle (not being a private motor vehicle or permitted commercial motor vehicle) on any parking space in a communal area (including a standard off-highway parking space) or on a highway.
- 11.7 Not to carry out any works of repair on any parking space within the Unit or on a communal area (including a standard off-highway parking space) or a highway:
- 11.7.1 in respect of any private motor vehicle or permitted commercial motor vehicle so as to be visible by the public; or
- 11.7.2 in respect of any other motor vehicle.
12. Not to use or permit any parking space designated by His Royal Highness as a visitor's parking space to be used other than for occasional visitor parking.
13. Not to permit any trailer caravan motorised caravan or boat or other similar thing to be brought onto the Unit or to be parked in any parking space within the Unit or any communal area or on a highway.
14. Not to erect or permit to be erected any aerial dish mast or cabling or other communications or receiver equipment or any other equipment machinery plant or system on the exterior of the Unit without His Royal Highness's prior consent.
15. Not to keep or leave any rubbish or refuse on or near to the Unit other than in a proper receptacle and only on the day stipulated for the collection of the same by the relevant collector of rubbish on the Estate.
16. To comply in respect of any implemented development with (as the case may be):
- 16.1 the LDO including the Design Manual or
- 16.2 the planning permissions relating to the unit
17. To comply with such covenants stipulations and regulations as to the amenity and use of the Estate as may be issued by His Royal Highness from time to time
18. To comply with the relevant Community Stakeholder Covenants as set out in any planning agreement or planning obligation in respect of the Estate
- 19.1 Upon notice from His Royal Highness of any breach of any obligation under this Schedule on the Unit to remedy the breach as quickly as reasonably practicable
- 19.2 If any breach has not been remedied in accordance with Paragraph 19.1 His Royal Highness and any persons authorised by him may upon reasonable prior written notice to the Owner enter the Unit (with plant equipment and machinery) and carry out works and take action to remedy the breach
- 19.3 To pay within 10 days of written demand all reasonable costs and expenses (plus VAT) incurred by His Royal Highness under Paragraph 19.2
20. Not to transfer or let the whole or any part of the Unit without procuring simultaneously with such transfer or lease that the transferee or tenant obtains a copy of the Design and Community Code and the Design Manual
21. The provisions of this Paragraph 21 apply to this Schedule:
- 21.1 Unit means a residential Unit a commercial Unit or a community facility
- 21.2 Owner means the owner of the relevant Unit at the relevant time

- 21.3 His Royal Highness means His Royal Highness The Prince of Wales and his successors as possessors of the Duchy of Cornwall
- 21.4 Design and Community Code means the code of design and community standards for the Estate in such form as is notified by His Royal Highness
- 21.5 LDO means the Nansledan Local Development Order 2021 (as varied from time to time) and Design Manual as the meaning under the Nansledan Development Order 2021
- 21.6 References to the Unit are references to the whole or any part of the Unit
- 21.7 An obligation not to do or omit to do any act or thing includes an obligation not to permit or allow that act or thing to be done or to be omitted to be done
- 21.8 Where under this Schedule reference is made to His Royal Highness's approval or consent:
- 21.8.1 His Royal Highness may appoint the Estate Company to act as his agent
- 21.8.2 every application for such approval or consent shall be in writing and shall be made to the Estate Company's management office as or as otherwise notified to the Owner
- 21.8.3 such approval or consent may be withheld in respect of any matter which is not consistent with or is in breach of the Design and Community Code or the Design Manual
- 21.8.4 such approval or consent shall not be unreasonably withheld save where any matter is not consistent with or is in breach of the Design and Community Code or the Design Manual
- 21.8.5 such approval or consent shall be in writing
- 21.8.6 His Royal Highness may where appropriate require the submission of proper drawings plans and specifications in respect of the application for approval or consent
- 21.8.7 His Royal Highness and the Estate Company shall not as a condition of approval or consent require the payment of any sum other than reasonable costs and expenses incurred by His Royal Highness and the Estate Company in respect of the application (whether or not approval or consent is given) and
- 21.8.8 His Royal Highness and the Estate Company shall be paid on demand the reasonable costs and expenses incurred by His Royal Highness and the Estate Company in respect of any application for any approval or consent under this Schedule
- 21.9 Any notice under this Schedule shall be in writing.
- 21.10 If any sum due to His Royal Highness or the Estate Company is not paid on the due date interest at the rate of 4% above the Bank of England base rate from time to time shall be payable to His Royal Highness or the Estate Company on that sum from the due date for payment to the date of payment

APPENDIX B

COMMUNITY STAKEHOLDER COVENANTS

Appendix B - Community Stakeholders Covenants

- 1 Not to cause any annoyance, inconvenience, injury, offence or nuisance to the Owners, the Occupiers, the Company or any other member of the general public.
 - 2 Not to cause any harassment on the grounds of age, gender, race, culture, ability or lifestyle.
 - 3 Not to act offensively, abusively or in an insulting manner.
 - 4 Not to cause offence through drunkenness.
 - 5 Not to damage or threaten to damage any person's property.
 - 6 Not to write graffiti.
 - 7 Not to make any unnecessary or excessive noise including by arguing or slamming of doors.
 8. Not to use or allow any part of the Site to be used for:
 - 8.1 dealing in, or the illegal use of, any controlled drugs; or
 - 8.2 prostitution.
 - 9 Not to cause any annoyance or nuisance by pets including barking and fouling.
 - 10 Not to play ball games close to a person's home in such a manner as to cause annoyance or nuisance.
 - 11 Not to deposit litter or items other than in appropriate receptacles.
 - 12 To procure that any tenants or other occupiers of the Property and any children of the Owners observe and perform these Regulations.
 - 13 To pay within 10 days of written demand all costs and expenses (plus VAT) incurred by the Company in enforcing these Regulations and remedying any breach of these Regulations.
- 14 Homeworking covenants**
- 14.1 Homeworking by members of households living in all Dwellings shall be encouraged subject to covenants:
 - 14.1.1 Not to use Dwellings for any employment purpose that is not ancillary to its use as a dwelling;
 - 14.1.1.2 Creates any noise, smells or other sources of annoyance to neighbours; or
 - 14.1.1.3 Results in a material increase in either the number of visitors received at the dwelling or the volume of goods delivered to or collected from the dwelling.
 - 14.1.2 Not to park any commercial vehicle (being any vehicle longer or higher than a large family estate car/MPV) on the roads or parking areas of Nansledan;
 - 14.1.3 Not to display any advertisements on any Dwelling or its curtilage; or
 - 14.1.4 Not to store any plant goods or materials in any garden, parking place or other open area.
- 15. Live Work Unit covenants**
- 15.1 Not to use the Live Work Unit for any purpose other than offices, small scale workshops or consulting rooms;
 - 15.2 Not to create any noise, smells or other sources of annoyance to neighbours;
 - 15.3 Not to carry out any activity that generates a significant number of car borne visitors or deliveries/collections in particular from large commercial vehicles (i.e. vehicles larger than a Ford Transit);
 - 15.4 Not to park any commercial vehicle (being any vehicle longer or higher than a large family estate car/MPV) on the roads or parking areas of Nansledan except in any space specifically designated for such parking;
 - 15.5 Not to carry out any retail sales except in Live Work Units specifically designated for that purpose; or
 - 15.6 Not to store any plant goods or materials in any garden, parking place or other open area.

APPENDIX C

LETTERING ON HOUSES AND STREETS

Appendix C - Lettering on Houses & Streets

C1 House Names

The naming of new houses in Nansledan will not be encouraged. This is because the affixing of nameplates to a house increases the visual clutter of the elevations.



Door with a full surround

Door with no surround

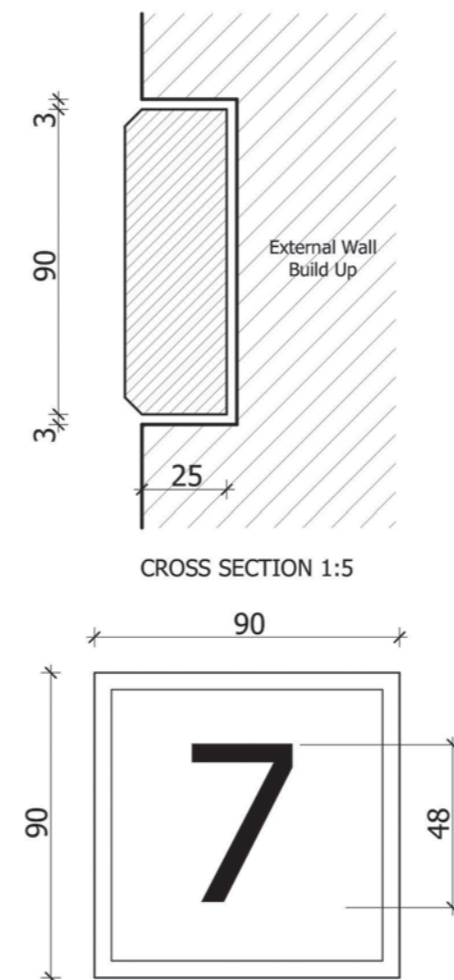

Door number detail

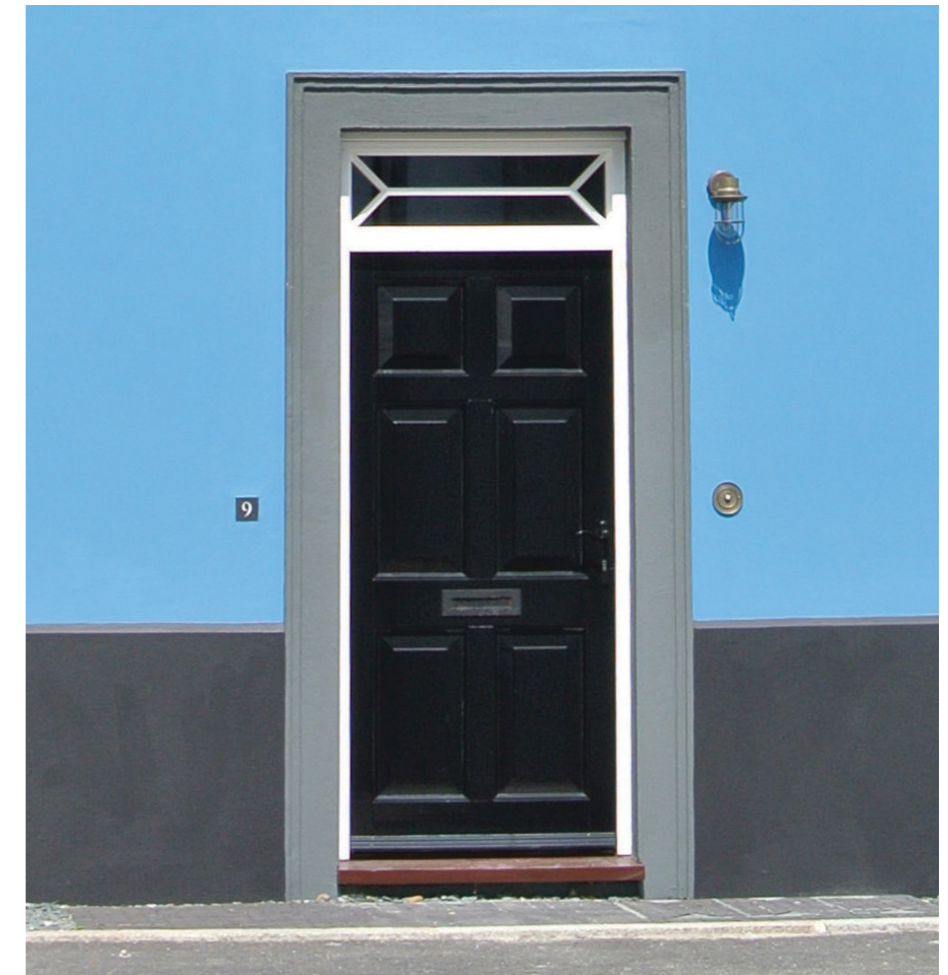

A simple, uncluttered door surround

Appendix C - Lettering on Houses & Streets

C2 Numbers and Street Names

House numbers and street names are consistent in position and design so that they may be readily identified particularly by emergency services. They are the responsibility of the Duchy. For your safety as for the convenience of the residents and visitors, they must not be obscured or altered in any way.

The general position for all numbers and door bells is 90mm from the door frame and 1,500mm above the door cill. They are generally symmetrical with one on each side of the door.

Wherever possible street names are positioned on buildings. The architectural style of the overall building will govern the precise location of street names. However, where possible, the height of street names is equally spaced between the head of the ground floor window and cill of the first floor window, and the distance from the corner of a building is 500mm. Street names at a corner are the same height above ground and the same distance from the corner.

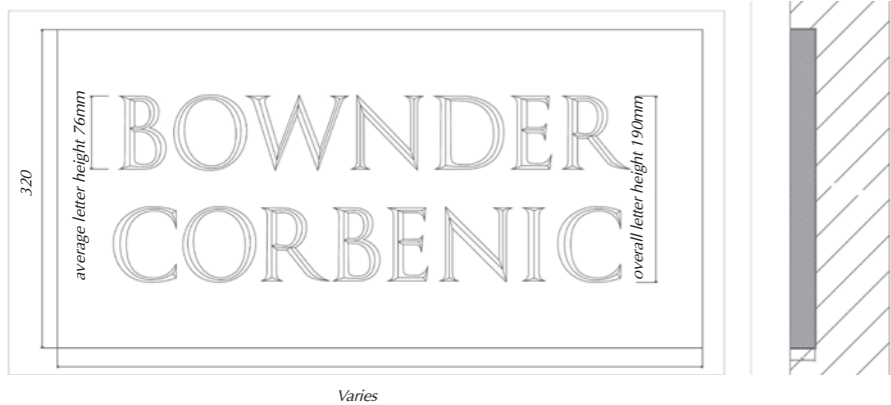

Street names: 25mm slate resin bonded into wall



Examples of slate street names affixed to walls

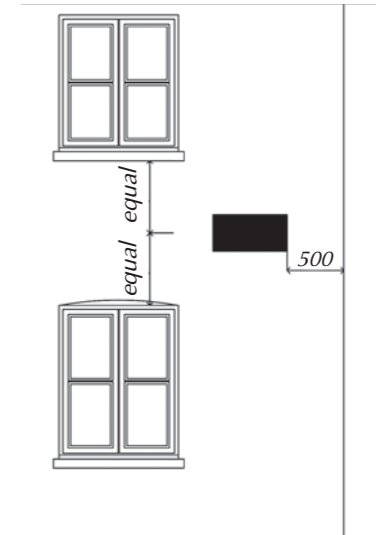

APPENDIX D

LETTERING ON SHOPFRONTS

Appendix D - Lettering on Shopfronts

D1. Poorly designed shopfronts and shop windows have devalued the character of many traditional shopping streets. New shopfront design must respect the scale and proportions of the streetscape by maintaining the existing grain of development along the street and respecting the appropriate plot width. An important principle in Nansledan is to separate fascias one from another, allowing the buildings to reach the ground. The size and subdivision of the display windows at Nansledan is subject to the basic principle that no single pane of glass may be larger than 4.0 sqm. The proportion of the window opening, its subdivision, its relation to and the design of the shop door, fascia and stall-riser, all require careful consideration. The architectural style of the overall building will govern the detailing of the shopfront, to produce a harmonious whole, which will create a valuable marketing image.

- a. Materials must be used for the shopfront that are consistent with the rest of the building. Generally, shopfronts shall be built predominantly of timber or of timber and cast-iron or cast aluminium above the plinth. The display window should be integrated with the door and the fascia with a single construction and painted with classic dark tones, or occasionally pastel colours may be accepted. All colours must be approved by the Duchy. The shopfront shall extend no nearer than 500 mm to the centre line of the party wall.
- b. Generally, commercial fascias shall be in the proportion of 1:8 with the total height of the shopfront. Fascia panels should not fill the whole length of the building. Fascias should not, as far as possible, be in a vertical plane, but should incline by about 10 degrees from the vertical towards the street. The façades of the Art Deco buildings incorporate a fascia band.
- c. Shop awnings shall be constructed of canvas on a retractable frame with a blind box fitted as an integral part of the shopfront design.
- d. All lettering, numbering and commercial fascias are to comply with the seven principles – see below.

The Building Code provides further guidance on the design of shopfronts:

D2. Lighting of signs, shopfronts and business premises brings life to a town at night. Carefully designed and sited external



illuminations, from flood and spots lights, can enhance the architectural qualities of the building, in addition to lighting a sign or fascia. However, the use of over intense lighting, or internally illuminated signs, can create a confusing background, which harms the architectural quality of the buildings. 'Borrowed lighting' falling on footpaths or entrances supplements that from public lighting fittings and lamp posts, deterring crime. All fittings must be simply designed, of good proportion, and painted black. Over-elaborate and brass brackets and lanterns will not be permitted.

D3. Hanging signs are a traditional means of identification for business premises and also add to the richness of the townscape. They are particularly effective in narrow streets, where wide fascias may not be legible when viewed at an acute angle. Subject to their not posing an obstruction to traffic, well designed hanging signs are encouraged at Nansledan.

D4. The Eight principles set out below must be taken into account when preparing and submitting applications for shopfronts, fascias, signs, hanging signs or other business identification.

Appendix D - Lettering on Shopfronts

1. Lettering on external walls of any business premises.

Height from ground to top edge of letters or fascia panel should respect the design of the existing building, but should not normally exceed 2,500 mm.

2. Lettering on windows of business premises.

On the Art Deco buildings letter will be permitted on the shop or business windows.

3. Fascia panel or applied letters of business name.

Length should not exceed 75% of the width of the building. Fascia panels or applied letters should not come closer to the sides of any facade than 500 mm. Pilasters may be used as side framing for the shopfront and to give a visual support for the fascia. Fascia panels will not be permitted on the Art Deco buildings.



The dimensions shown above are from the Baskerville font, and where a letter style is created - as by a signwriter - these dimensions are recommended. Exaggerated ascenders and descenders of some script typefaces and letter styles should be controlled so that they do not become disproportionate to the capital letter height.

4. Lettering

Maximum capital letter height 180 mm. See illustration for related lower case sizes.

5. Hanging signs

Height from ground to top edge of the sign should not normally exceed 3,300 mm. Extending 750 mm maximum wall to front edge. Capable of being contained in a square 750 mm x 750 mm.

6. Lighting

Lettering must be externally illuminated.

7. Glazing

Maximum area for any single pane of glass 4.0 sqm.

8. Stall risers

500 mm minimum height is normally required.

D5. The initial installation of a shopfront, and its subsequent alteration will require planning permission from Cornwall Council. The initial installation of a hanging illuminated sign, or illumination of a fascia will also require planning permission from Cornwall Council. Subsequent modification of the content of the sign, for example if the business occupancy changes, may benefit from 'deemed consent' under the Advertisements Regulations, 1992. Applicants are advised to check with the Council to confirm whether an application for express consent is required in particular circumstances.

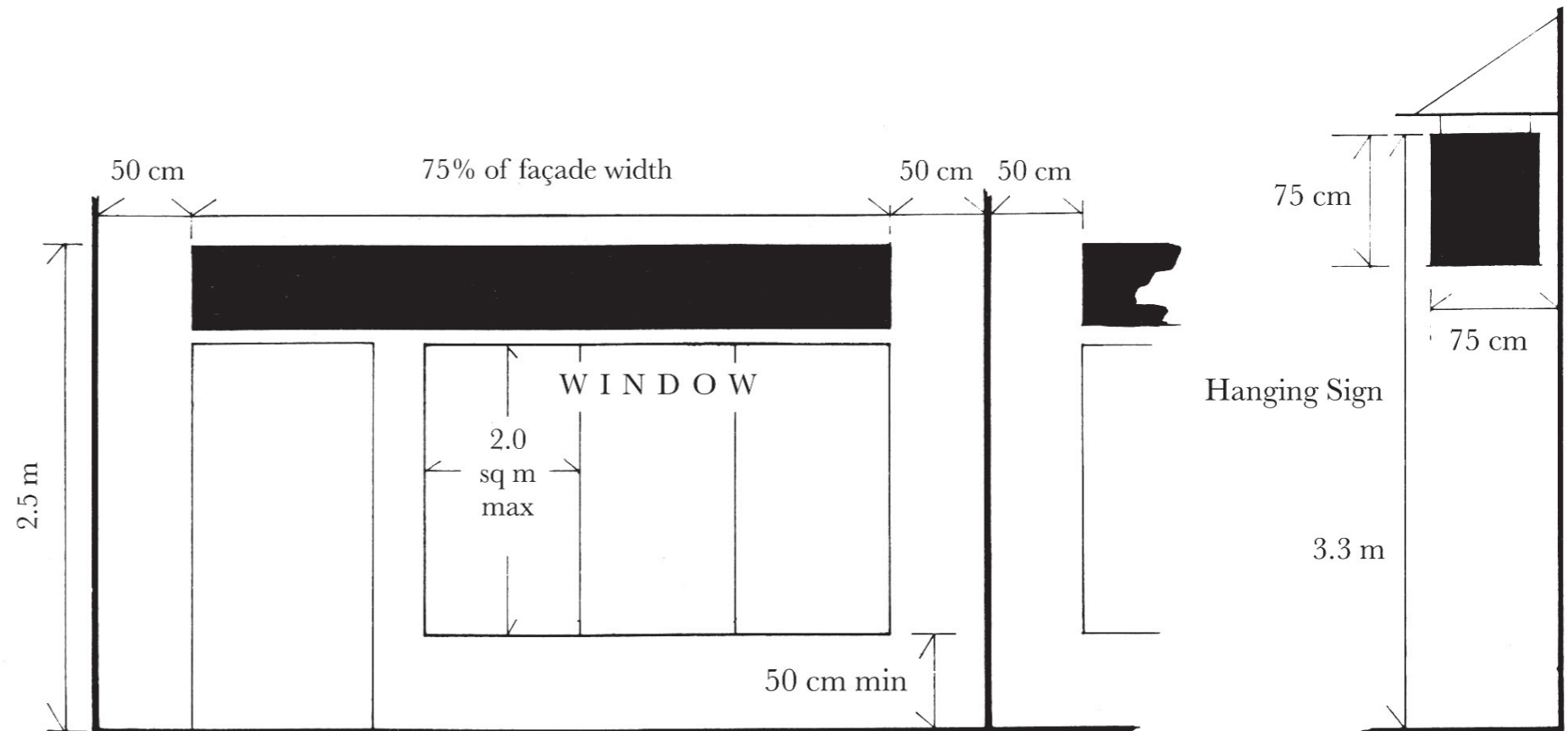

APPENDIX E

APPROVED PAINT COLOURS

Appendix E - Approved Paint Colours







In the course of constructing Nansledan, a palette of paint colours has been selected to accentuate the seaside character of the area. The colours are varied but emphasise schemes of white, cream or pastel colours.

If you wish to paint your house a new colour, consent from the Duchy is required. However, selecting a choice from the below colours will lead to a likely consent by the Duchy provided it is both acceptable to your neighbours and, in the Duchy's opinion, is sympathetic to the composition of the street scene. A change of colour to render or painted brick houses may necessitate a change of colour to the front door.

SANDTEX X-TREME X-POSURE SMOOTH

W1210D		RAL5024		N4611P	
P2331L		RAL3015		L6571Q	
B7801H		RAL6019		L4741B	
A1570R		RAL7031		L7621V	
A1740V		RAL1001		X6610S	
RAL1015		B6770Y		X1640V	
RAL9001		B8870L		Z0660N	
RAL9003		B1820Q		TBC	
RAL9010		A6830S		F1390U	
RAL6034		N8700Z		A1510D	

SANDOLIN BEAUTIFLEX

RAL5001		RAL6005**		N5203Y	
RAL5002		RAL3003**		M1393S	
RAL5012		RAL3005**		F1390U	
RAL5013		W6072V**		F3001	
RAL5024		X3093Y**		D3491C	
RAL6034		X5124Q**		D5261H	
RAL6003		B8870L		G9351H	
RAL9001		B1820Q		G3061A	
RAL9003		N3452K		C8851K	
RAL9010		N5274H		G8530S	
RAL7021		N8132S		G9300S	
RAL7031		NPO15Q		H8120V	
RAL7046		L9192N		RAL1015	

Printed by Nationwide Print using traditional skills and modern technology.

Our presses are 95% powered by our 200 solar energy panels, we have sensor lighting and have a newly installed insulated roof and windows.

The printing inks are made using vegetable-based oils. As many waste elements as possible associated with this product will be recycled.

Nationwide Print understands that common business practices can adversely affect the environment and therefore we continually strive to reduce our impact on the environment not only in the methods we work but also by the way we procure any products and services required to fulfil the work we carry out.

The paper used for this publication is made from 100% recovered fibre. It is called Revive 100% Recycled and is made from 100% recycled fibre, FSC® certified, very high whiteness (CIE 150) minimising negative impacts on the environment.



DUCHY *of* CORNWALL

